

DESIGN OF THE QUESTION PAPER
PHYSICS - CLASS XII

Time : 3 Hrs.

Max. Marks : 70

The weightage of the distribution of marks over different dimensions of the question paper shall be as follows:

A. Weightage to content/ subject units

<u>Unit</u>	<u>Marks</u>
Electrostatics	08
Current Electricity	07
Magnetic Effect of Current & Magnetism	08
Electromagnetic Induction and Alternating current	08
Electromagnetic Waves	03
Optics	14
Dual Nature of Matter	04
Atoms and Nuclei	06
Electronic Devices	07
Communication Systems	05
Total	70

B. Weightage to form of questions

S.No.	Form of Questions	Marks for each Question	No. of Questions	Total Marks
1.	Long Answer Type (LA)	5	3	15
2.	Short Answer (SA I)	3	09	27
3.	Short Answer (SA II)	2	10	20
4.	Very Short Answer (VSA)	1	08	08
	TOTAL	-	30	70

C. Scheme of Options

1. There will be no overall option.
2. Internal choices (either / or type) on a very selective basis has been given in five questions. This internal choice is given in any one question of 2 marks, any one question of 3 marks and all three questions of 5 marks weightage.

D. A Weightage of about 15 marks in total, has been assigned to numericals

E. Weightage to difficulty level of questions.

<u>S.No.</u>	<u>Estimated difficulty level</u>	<u>Percentage</u>
1.	Easy	15
2.	Average	70
3.	Difficult	15

A weightage of 20% has been assigned to questions which test higher order thinking skills of students.

Class XII
Physics
BLUE-PRINT I

S.NO.	UNIT	VSA (1 Marks)	SA I (2 Marks)	SAII (3 Marks)	LA (5 Marks)	TOTAL
1.	Electrostatics	-	2 (1)	6 (2)	-	8 (3)
2.	Current Electricity	-	4(2)	3(1)	-	7(3)
3.	Magnetic effect of Current and Magnetism	1(1)	2(1)	-	5(1)	8(3)
4.	Electromagnetic Induction & Alternating currents	2(2)	-	6(2)	-	8(4)
5.	Electromagnetic Waves	1(1)	2(1)	-	-	3(2)
6.	Optics	1(1)	2(1)	6(2)	5(1)	14(5)
7.	Dual nature of Matter	-	4(2)	-	-	4(2)
8.	Atoms and Nuclei	1(1)	2(1)	3(1)	-	6(3)
9.	Electronic Devices	2(2)	-	-	5(1)	7(3)
10.	Communication systems	-	2(1)	3(1)	-	5(2)
	Total	8(8)	20(10)	27(9)	15(3)	70(30)

SAMPLE PAPER I
XII - PHYSICS

Time : Three Hours

Max. Marks : 70

General Instructions

- (a) All questions are compulsory.
- (b) There are 30 questions in total. Questions 1 to 8 carry one mark each, questions 9 to 18 carry two marks each, questions 19 to 27 carry three marks each and questions 28 to 30 carry five marks each.
- (c) There is no overall choice. However, an internal choice has been provided in one question of two marks, one question of three marks and all three questions of five marks each. You have to attempt only one of the given choices in such questions.
- (d) Use of calculators is not permitted.
- (e) You may use the following physical constants wherever necessary :

$$\begin{aligned}c &= 3 \times 10^8 \text{ms}^{-1} \\h &= 6.6 \times 10^{-34} \text{Js} \\e &= 1.6 \times 10^{-19} \text{C} \\\mu_0 &= 4\pi \times 10^{-7} \text{T m A}^{-1}\end{aligned}$$

$$\text{Boltzmann constant } k = 1.38 \times 10^{23} \text{JK}^{-1}$$

$$\text{Avogadro's number } N_A = 6.023 \times 10^{23} / \text{mole}$$

$$\text{Mass of neutron } m_n = 1.6 \times 10^{-27} \text{kg}$$

- 1. Two identical charged particles moving with same speed enter a region of uniform magnetic field. If one of these enters normal to the field direction and the other enters along a direction at 30° with the field, what would be the ratio of their angular frequencies?
- 2. Why does a metallic piece become very hot when it is surrounded by a coil carrying high frequency alternating current?
- 3. How is a sample of an n-type semiconductor electrically neutral though it has an excess of negative charge carriers?
- 4. Name the characteristics of electromagnetic waves that
 - (i) increases
 - (ii) remains constantin the electromagnetic spectrum as one moves from radiowave region towards ultraviolet region.
- 5. How would the angular separation of interference fringes in young's double slit experiment change when the distance of separation between the slits and the screen is doubled?
- 6. Calculate the ratio of energies of photons produced due to transition of electron of hydrogen atom from its,
 - (i) Second permitted energy level to the first level, and
 - (ii) Highest permitted energy level to the second permitted level
- 7. Give expression for the average value of the a c voltage
$$V = V_0 \text{Sin } \omega t$$

over the time interval $t = 0$ and $t = \frac{\pi}{\omega}$

8. How is the band gap, E_g , of a photo diode related to the maximum wavelength, λ_m , that can be detected by it?
9. Keeping the voltage of the the charging source constant, what would be the percentage change in the energy stored in a parallel plate capacitor if the separation between its plates were to be decreased by 10%?
10. Explain how the average velocity of free electrons in a metal at constant temperature, in an electric field, remain constant even though the electrons are being constantly accelerated by this electric field?
11. How is the resolving power of a microscope affected when,
 - (i) the wavelength of illuminating radiations is decreased?
 - (ii) the diameter of the objective lens is decreased?
 Justify your answer.
12. What is the basic difference between the atom or molecule of a diamagnetic and a paramagnetic material? Why are elements with even atomic number more likely to be diamagnetic?
13. Why are infrared radiations referred to as heat waves also? Name the radiations which are next to these radiations in electromagnetic spectrum having
 - (i) Shorter wavelength.
 - (ii) Longer wavelength.
14. The following data was recorded for values of object distance and the corresponding values of image distance in the experiment on study of real image formation by a convex lens of power +5D. One of these observations is incorrect. Identify this observation and give reason for your choice:

S.No.	1	2	3	4	5	6
Object distance (cm)	25	30	35	45	50	55
Image distance (cm)	97	61	37	35	32	30

15. Two students X and Y perform an experiment on potentiometer separately using the circuit diagram shown here.

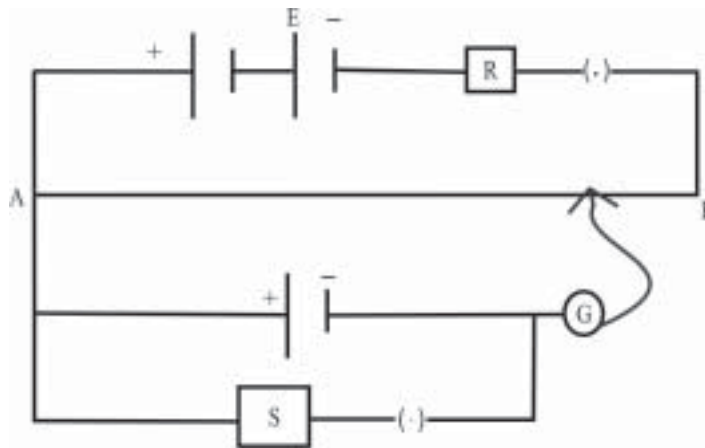

Keeping other things unchanged

(i) X increases the value of distance R

(ii) Y decreases the value of resistance S in the set up.

How would these changes affect the position of null point in each case and why?

16. The following table gives the values of work function for a few photo sensitive metals

S.No.	Metal	Work Function (eV)
1.	Na	1.92
2.	K	2.15
3.	Mo	4.17

If each of these metals is exposed to radiations of wavelength 300 nm, which of them will not emit photo electrons and why?

OR

By how much would the stopping potential for a given photosensitive surface go up if the frequency of the incident radiations were to be increased from 4×10^{15} Hz to 8×10^{15} Hz?

Given $h = 6.4 \times 10^{-34}$ J-s, $e = 1.6 \times 10^{-19}$ C and $c = 3 \times 10^8$ ms⁻¹

17. Prove that the instantaneous rate of change of the activity of a radioactive substance is inversely proportional to the square of its half life.

18. What does the term LOS communication mean? Name the types of waves that are used for this communication. Which of the two-height of transmitting antenna and height of receiving antenna - can affect the range over which this mode of communication remains effective?

19. The following data was obtained for the dependence of the magnitude of electric field, with distance, from a reference point O, within the charge distribution in the shaded region.

Field Point	A	B	C	A'	B'	C'
Magnitude of electric field	E	E/8	E/27	E/2	E/16	E/64

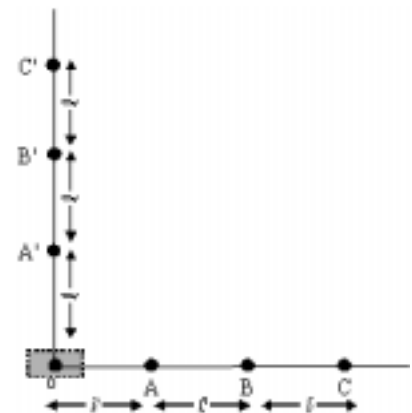

(i) Identify the charge distribution and justify your answer.

(ii) If the potential due to this charge distribution, has a value V at the point A, what is its value at the point A' ?

20. A charge Q located at a point \vec{r} is in equilibrium under the combined electric field of three charges q_1, q_2, q_3 . If the charges q_1, q_2 are located at points \vec{r}_1 and \vec{r}_2 respectively, find the direction of the force on Q , due to q_3 in terms of $q_1, q_2, \vec{r}_1, \vec{r}_2$ and \vec{r} . 3

21. 12 cells, each of emf 1.5V and internal resistance $0.5\ \Omega$, are arranged in m rows each containing n cells connected in series, as shown. Calculate the values of n and m for which this combination would send maximum current through an external resistance of $1.5\ \Omega$.

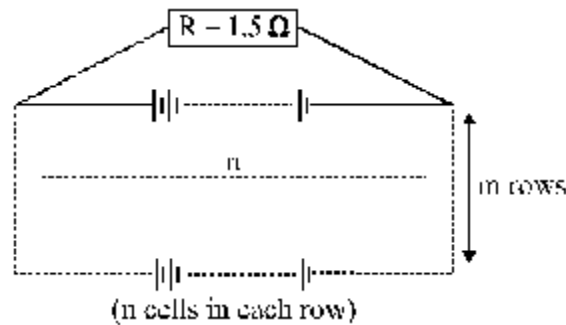

OR

For the circuit shown here, calculate the potential difference between points B and D

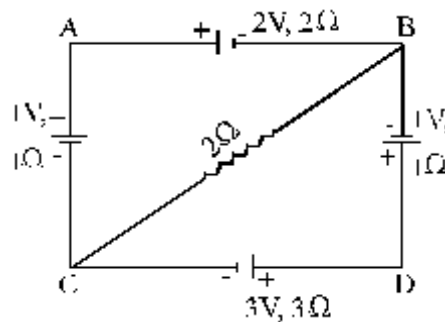

22. A beam of light of wavelength 400 nm is incident normally on a right angled prism as shown. It is observed that the light just grazes along the surface AC after falling on it. Given that the refractive index of the material of the prism varies with the wavelength λ as per the relation $\mu_A = 1.2 + \frac{b}{\lambda^2}$

calculate the value of b and the refractive index of the prism material for a wavelength $\lambda = 5000\ \text{\AA}$.

[(Given $\theta = \text{Sin}^{-1}(0.625)$)]

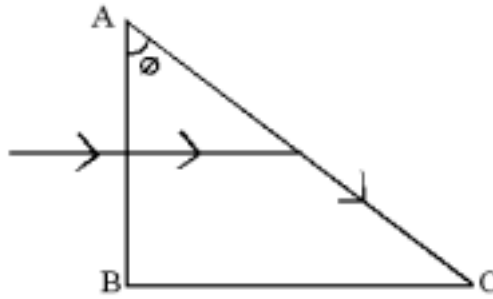

3

23. Three students X, Y, and Z performed an experiment for studying the variation of alternating currents with angular frequency in a series LCR circuit and obtained the graphs shown below. They all used a.c. sources of the same r. m. s. value and inductances of the same value.
 What can we (qualitatively) conclude about the
 (i) capacitance value
 (ii) resistance values
 used by them? In which case will the quality factor be maximum?
 What can we conclude about nature of the impedance of the set up at frequency ω_0 ?

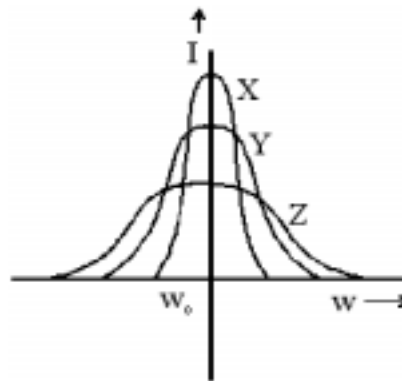

3

24. An equiconvex lens with radii of curvature of magnitude r each, is put over a liquid layer poured on top of a plane mirror. A small needle, with its tip on the principal axis of the lens, is moved along the axis until its inverted real image coincides with the needle itself. The distance of the needle from the lens is measured to be ' a '. On removing the liquid layer and repeating the experiment the distance is found to be ' b '.
 Given that two values of distances measured represent the focal length values in the two cases, obtain a formula for the refractive index of the liquid.

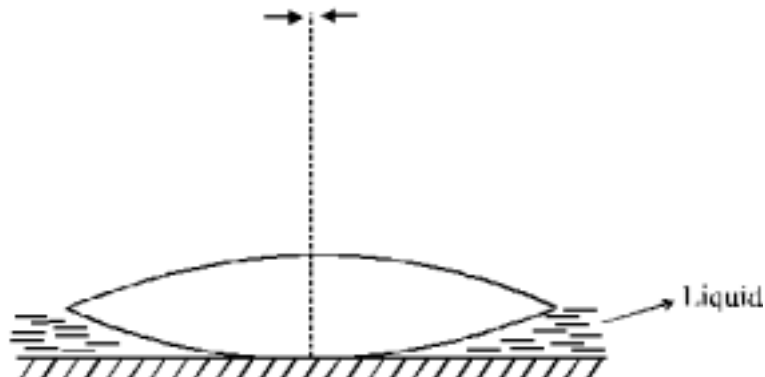

3

25. A circular coil having 20 turns, each of radius 8 cm, is rotating about its vertical diameter with an angular speed of 50 radian s^{-1} in a uniform horizontal magnetic field of magnitude 30 mT. Obtain the maximum average and r. m. s. values of the emf induced in the coil.
If the coil forms a closed loop of resistance 10Ω , how much power is dissipated as heat in it? 3

26. The nucleus of an atom of ${}_{92}^{235}\text{Y}$, initially at rest, decays by emitting an α -particle as per the equation

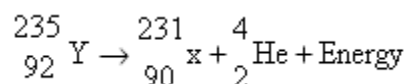

It is given that the binding energies per nucleon of the parent and the daughter nuclei are 7.8 MeV and 7.835 MeV respectively and that of α -particle is 7.07 MeV/nucleon. Assuming the daughter nucleus to be formed in the unexcited state and neglecting its share in the energy of the reaction, calculate the speed of the emitted α -particle. Take mass of α -particle to be $6.68 \times 10^{-27} \text{ kg}$. 3

27. Define the term 'modulation index' for an AM wave. What would be the modulation index for an AM wave for which the maximum amplitude is 'a' while the minimum amplitude is 'b'? 3

28. Two circular coils X and Y having radii R and $\frac{R}{2}$ respectively are placed in horizontal plane with their centres coinciding with each other. Coil X has a current I flowing through it in the clockwise sense. What must be the current in coil Y to make the total magnetic field at the common centre of the two coils, zero?

With the same currents flowing in the two coils, if the coil Y is now lifted vertically upwards through a distance R , what would be the net magnetic field at the centre of coil Y?

OR

A straight thick long wire of uniform cross section of radius 'a' is carrying a steady current I . Use Ampere's circuital law to obtain a relation showing the variation of the magnetic field (B_r) inside and outside the wire with distance r , ($r \leq a$) and ($r > a$) of the field point from the centre of its cross section. Plot a graph showing the nature of this variation.

Calculate the ratio of magnetic field at a point $\frac{a}{2}$ above the surface of the wire to that at a point $\frac{a}{2}$ below its surface. What is the maximum value of the field of this wire? 5

29. State the principle which helps us to determine the shape of the wavefront at a later time from its given shape at any time. Apply this principle to

- (i) Show that a spherical/ plane wavefront continues to propagate forward as a spherical/plane wave front.
(ii) Derive Snell's law of refraction by drawing the refracted wavefront corresponding to a plane wavefront incident on the boundary separating a rarer medium from a denser medium. 5

OR

What do we understand by 'polarization' of a wave? How does this phenomenon help us to decide whether a

given wave is transverse or longitudinal in nature?

Light from an ordinary source (say a sodium lamp) is passed through a polaroid sheet P_1 . The transmitted light is then made to pass through a second polaroid sheet P_2 which can be rotated so that the angle (θ) between the two polaroid sheets varies from 0° to 90° . Show graphically the variation of the intensity of light, transmitted by P_1 and P_2 , as a function of the angle θ . Take the incident beam intensity as I_0 . Why does the light from a clear blue portion of the sky, show a rise and fall of intensity when viewed through a polaroid which is rotated? 5

30. A student has to study the input and output characteristics of a n-p-n silicon transistor in the Common Emitter configuration. What kind of a circuit arrangement should she use for this purpose?

Draw the typical shape of input characteristics likely to be obtained by her. What do we understand by the cut off, active and saturation states of the transistor? In which of these states does the transistor not remain when being used as a switch?

OR

Input signals A and B are applied to the input terminals of the 'dotted box' set-up shown here. Let Y be the final output signal from the box.

Draw the wave forms of the signals labelled as C_1 and C_2 within the box, giving (in brief) the reasons for getting these wave forms. Hence draw the wave form of the final output signal Y. Give reasons for your choice.

What can we state (in words) as the relation between the final output signal Y and the input signals A and B ?

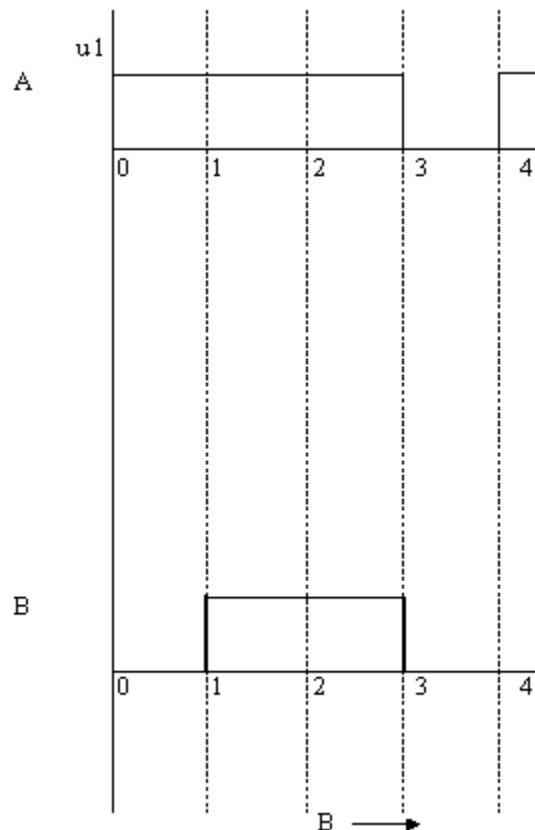

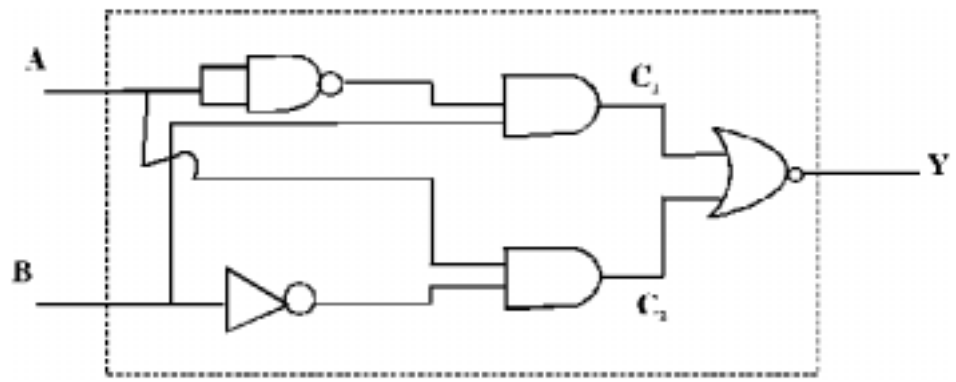

Q. No.	Value Points	Marks
	$= \frac{hc}{\lambda}$ $= \frac{6.4 \times 10^{-34} \times 3 \times 10^8}{300 \times 10^{-9} \times 1.6 \times 10^{-19}} eV = 4eV$	1
	This being less than the work function of Mo, there would be no photo-emission from Mo.	
	OR	
	$eV_s = hv - w$	1/2
	$\therefore e(V_2 - V_1) = h(v_2 - v_1)$	
	$\text{or } V_2 - V_1 = \frac{h}{e}(v_2 - v_1)$	1/2
	$\therefore V_2 - V_1 = \frac{6.4 \times 10^{-34}}{1.6 \times 10^{-19}} (8 - 4) \times 10^{15} \text{ volt} = 16 \text{ volt}$	1
17.	<p>Instantaneous Activity = $R = -\frac{dN}{dt} = \lambda N$</p> $\therefore \frac{dR}{dt} = \frac{d}{dt}(\lambda N) = \lambda \frac{dN}{dt}$ $= \lambda(-\lambda N) = -\lambda^2 N$ $= -\left(\frac{\log e^2}{T_{1/2}}\right)^2 N$ $\therefore \frac{dR}{dt} \propto \frac{1}{(T_{1/2})^2}$	1/2 1/2 1/2
18.	<p>LOS → line of sight</p> <p>Waves used → space waves</p> <p>It is both - the height of transmitting antenna as well as the height of the receiving antenna that affects the range of the mode of communication.</p>	1/2 1/2 1
19.	<p>We observe that the field magnitude</p> <p>(i) Varies as the inverse cube of the distance of the field point along one line.</p> <p>(ii) Has a magnitude half of its magnitude (at an equidistant point) on the line perpendicular to this line.</p>	1/2 1/2
	These properties tell us that the given charge distribution is a (small) electric dipole centered at the reference point O. The point A' is an equatorial points for the given dipole. Hence potential of A' = zero. 1	

Q. No.	Value Points	Marks
20.	We have $\vec{F}_1 = \frac{1}{4\pi\epsilon_0} \frac{Qq_1}{ \vec{r} - \vec{r}_1 ^3} (\vec{r} - \vec{r}_1)$	1/2
	and $\vec{F}_2 = \frac{1}{4\pi\epsilon_0} \frac{Qq_2}{ \vec{r} - \vec{r}_2 ^3} (\vec{r} - \vec{r}_2)$	1/2
	For equilibrium, we must have $\vec{F}_3 + \vec{F}_1 + \vec{F}_2 = 0$ $\text{or } \vec{F}_3 = -(\vec{F}_1 + \vec{F}_2)$	1/2
	Hence $\vec{F}_3 = \frac{Q}{4\pi\epsilon_0} \left[\frac{q_1}{ \vec{r} - \vec{r}_1 ^3} (\vec{r}_1 - \vec{r}) + \frac{q_2}{ \vec{r} - \vec{r}_2 ^3} (\vec{r}_2 - \vec{r}) \right]$	1/2
	\therefore The direction of \vec{F}_3 is given by the direction of the vector	
	$\left[\frac{q_1}{ \vec{r} - \vec{r}_1 ^3} (\vec{r}_1 - \vec{r}) + \frac{q_2}{ \vec{r} - \vec{r}_2 ^3} (\vec{r}_2 - \vec{r}) \right]$	1
21.	The equivalent internal resistance of each row of n cells in series = nr.	
	\therefore The net equivalent internal resistance of the combination = $\frac{nr}{m}$	1/2
	Net equivalent emf of the combination = n x E (E = emf of one cell)	
	\therefore Current drawn by R	
	$= \frac{nE}{R + \frac{nr}{m}} = \frac{mnE}{mR + nr} = \frac{NE}{mR + nr}$ $= \frac{NE}{(\sqrt{mR} - \sqrt{nr})^2 + \sqrt{2mnRr}} = \frac{NE}{(\sqrt{mR} - \sqrt{nr})^2 + \sqrt{2NRr}}$	
	For maximum current, the denominator should be minimum.	
	This happens when, $\sqrt{mR} = \sqrt{nr}$ or $R = \frac{nr}{m}$	1

Q. No.

Value Points

Marks

$$\therefore \frac{n \times 0.5}{m} = 1.5 \text{ or } \frac{n}{m} = 3$$

$$\text{Also } n \times m = 12 \text{ (given).}$$

$$\text{Solving, we get } \underline{n = 6} \text{ and } \underline{m = 2}$$

1

OR

We can draw the circuit explicitly as shown. The current distribution can be taken as shown. Applying Kirchoff's second law to loops BADB and DCBD, respectively, we get the equations:

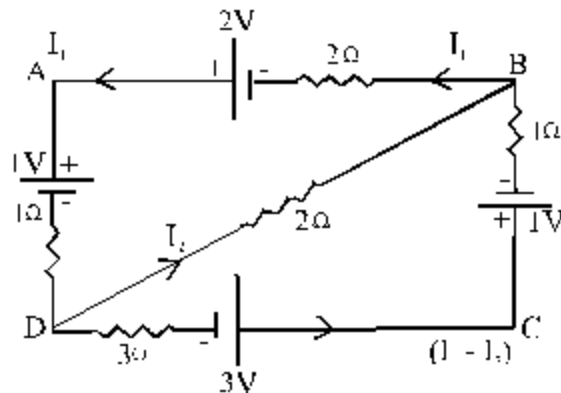

1/2

$$-2I_1 + 2 - 1 - 1 \times I_1 - 2I_2 = 0 \quad \text{or} \quad 3I_1 + 2I_2 = 1 \therefore$$

1/2

$$\text{and, } -3(I_1 - I_2) + 3 - 1 - 1 \times (I_1 - I_2) + 2I_2 = 0 \quad \text{or} \quad 4I_1 - 6I_2 = 2$$

1/2

$$\text{Solving, we get } I_1 = \frac{5}{13} \text{ A and } I_2 = \frac{1}{13} \text{ A}$$

1

$$\therefore \text{ P.D. between B and D} = 2 \times \frac{1}{13} \text{ V} = \frac{2}{13} \text{ V} = \underline{\underline{0.154 \text{ V}}}$$

1/2

(Point B is at a higher potential w. r. t. point D)

22. The ray must fall on the surface AC at just the critical angle, θ_c . The angle of incidence at the face AC equals θ

Hence $\theta = \theta_c$.

1

$$\therefore \mu = \frac{1}{\sin \theta_c} = \frac{1}{0.625} = 1.6$$

1/2

$$\therefore 1.6 = 1.2 + \frac{b}{(4 \times 10^{-7})^2}$$

1/2

$$\therefore b = 0.4 \times 16 \times 10^{-14} \text{ m}^2 = 6.4 \times 10^{-14} \text{ m}^2$$

1/2

The refractive index for $\lambda = 5000 \text{ \AA}$ is given by

Q. No.	Value Points	Marks
	$\mu^1 = 1.2 + \frac{6.4 \times 10^{-14}}{(5 \times 10^{-7})^2} = 1.2 + \frac{6.4}{25}$ $= 1.2 + 0.256 = \underline{\underline{1.456}}$	1/2
23.	(i) We have $C_1 = C_2 = C_3$	1/2
	Resonant frequency $= \frac{1}{2\pi\sqrt{LC}}$ is same for all three and we are given that L has same value for all	1/2
	(ii) We have $R_1 < R_2 < R_3$ Band width for X < Bandwidth for Y < Bandwidth for Z Max. current for X > Max. current for Y > Max. current for Z	1/2
	Student X has the maximum value for the quality factor because the bandwidth is least in this case.	1/2
	The impedance at the resonant frequency ω_0 is purely resistive in nature.	1/2
24.	The liquid layer can be regarded as forming a plane concave lens. The first value (= a) of the measured distance is, therefore, the focal length of the combination of the given lens and the liquid lens. The second value (= b) represents the focal length of the lens itself. Hence, if f = 16 is the focal length of the liquid lens, we have	
	$\frac{1}{a} = \frac{1}{b} + \frac{1}{f} \quad \text{or} \quad \frac{1}{f} = \frac{1}{a} - \frac{1}{b} = \left(\frac{b-a}{ab} \right)$	1/2
	But, $\frac{1}{f} = (\mu - 1) \left(-\frac{1}{R} + \frac{1}{\infty} \right) = \left(\frac{\mu - 1}{-R} \right)$ 1	
	$\therefore \frac{(b-a)}{ab} = \frac{(\mu-1)}{-R}, \quad \mu = \frac{R(a-b)}{ab} = 1$	1/2
25.	When the normal to the plane of the coil makes an angle θ with the direction of the magnetic field, the flux linked with it is	
	$\phi = NBA \cos \theta$	
	$= NBA \cos \omega t$	1/2
	\therefore Induced Emf $= -\frac{d\phi}{dt} = NBA\omega \sin \omega t$	1/2
	\therefore Max. Emf $= NBA\omega = NB(\pi r^2)\omega$	
	$= 20 \times 30 \times 10^{-3} \times \pi (8 \times 10^{-2})^2 \times 50$ volt	1/2
	$\equiv 0.603$ volt	
	Average Emf = Average of $\sin \omega t$ over a cycle = Zero	1/2
	rms value of Emf $= \frac{\text{Max. Emf}}{\sqrt{2}} = \frac{0.603}{\sqrt{2}}$ volt = 0.426V	1/2

Q. No.	Value Points	Marks
	Power dissipated = $\frac{(E_{rms})^2}{R} = \frac{(0.426)^2}{10} \text{ W} = 0.018 \text{ W}$	1/2
26.	Total B.E. of parent Nucleus = 7.8 x 235 MeV = 1833MeV	1/2
	Total B.E. of daughter nucleus = 7.835 x 231 MeV = 1809.9MeV	1/2
	Total B.E. of α -particle = 7.07 x 4 MeV = 28.28 MeV	1/2
	Increase in B.E. after the reaction = [(180.9+28.28) - (1833)]MeV = 5.18 MeV	
	This is the energy released in the reaction, since it assumed to be taken up totally by the α -particle,	
	$\frac{1}{2} mv^2 = 5.18 \times 1.6 \times 10^{-13} \text{ J}$	1/2
	$\therefore v^2 = \frac{5.18 \times 3.2}{6.68} \times 10^{14} \text{ m}^2 \text{ s}^{-2}$	
	$= \sqrt{2.48 \times 10^7} \text{ m s}^{-1}$	
	$\therefore \cong 1.58 \times 10^7 \text{ m s}^{-1}$	1/2
27.	The modulation index (μ) for an AM wave equals the ratio of the peak value of the modulating signal (A_m) to the peak value of the carrier wave (A_c) $\mu = \frac{A_m}{A_c}$	
	Given that $\left. \begin{array}{l} a = A_c + A_m \\ \text{and } b = A_c - A_m \end{array} \right]$	1/2
	$\therefore \left. \begin{array}{l} A_c = \frac{a+b}{2} \text{ and } A_m = \frac{a-b}{2} \end{array} \right]$	1/2
	$\therefore \mu = \frac{a-b}{a+b}$	1
28.	We have $\vec{B}_x = -\vec{B}_y$	1/2
	$\therefore \frac{\mu_o I}{2R} = \frac{\mu_o I'}{2 \cdot \frac{R}{2}} \text{ or } I' = I/2$	1/2

Q. No.

Value Points

Marks

The coil Y must carry this current in the anticlock wise sense. When the coil Y is lifted through a distance R, its centre becomes an axial point for coil X. Hence

$$B_{x'} = \frac{\mu_o I R^2}{2(R^2 + R^2)^{3/2}} = \frac{\mu_o I}{4\sqrt{2}R} = \frac{\mu I \sqrt{2}}{8R} \quad 1$$

Also

$$B_{y'} = \frac{\mu \frac{1}{2}}{2R \frac{1}{2}} = \frac{\mu_o I}{2R} \quad \frac{1}{2}$$

$$\begin{aligned} \therefore \text{Magnitude of net field} &= B_{y'} - B_{x'} = \frac{\mu_o I}{2R} \left(1 - \frac{\sqrt{2}}{4}\right) \\ &\equiv 0.323 \frac{\mu_o I}{R} \quad 1 \end{aligned}$$

This net field is in the direction of the field due to the coil Y, i.e; perpendicular to its plane and directed vertically upwards. 1

OR

Consider a closed path of radius r inside the cross section of the wire. The current enclosed by this path is

$$I' = \left(\frac{I}{\pi a^2}\right) \pi r^2 = I \frac{r^2}{a^2} \quad \frac{1}{2}$$

\therefore By Ampere's circuital law,

$$\oint \vec{B}_r \cdot d\vec{l} = \mu_o I' \quad \frac{1}{2}$$

or

$$B_r 2\pi r = \mu_o I \frac{r^2}{a^2}$$

$$\therefore B_r = \frac{\mu_o I}{2\pi a^2} r \quad \text{or } \underline{B \propto r} \text{ (for } r < a) \quad 1$$

Outside the wire, the field of the wire is given by

$$B \cdot 2\pi r = \mu_o I$$

or

$$B = \frac{\mu_o I}{2\pi r} \quad (r > a) \quad \frac{1}{2}$$

The relevant graph is, therefore, as shown.

Q. No.

Value Points

Marks

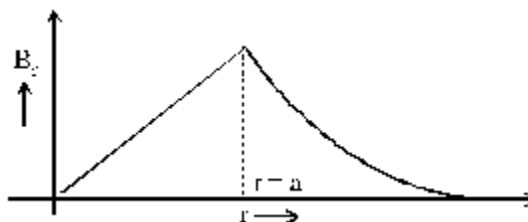

1

∴ If B_1 and B_2 , denote respectively, the values of the magnetic field at points $\frac{a}{2}$ above and $\frac{a}{2}$ below the surface of the wire, we have

$$\left. \begin{aligned} B_1 &= \frac{\mu_0 I}{2\pi \left(3\frac{a}{2}\right)} = \frac{\mu_0 I}{3\pi a} \\ \text{and } B_2 &= \frac{\mu_0 I}{2\pi a^2} = \frac{a}{2} = \frac{\mu_0 I}{4\pi a} \end{aligned} \right\} \frac{1}{2}$$

$$\therefore \frac{B_1}{B_2} = \frac{4}{3} \quad \frac{1}{2}$$

The maximum value of the field is at $r = a$. we have

$$B_{\max} = \frac{\mu_0 I}{2\pi a} \quad \frac{1}{2}$$

29. Statement of Huygen's Principle 1

Diagram showing the propagation of a spherical wavefront as a spherical wavefront. 1/2

Diagram showing the propagation of a plane wavefront as a plane wavefront 1/2

Diagram showing the incident and refracted wavefronts. 1/2

Derivation of Snell's law of refraction 1/2

OR

Meaning of the term 'polarization' 1

Polarization is possible only with transverse waves and not with longitudinal waves 1/2

Incident Intensity = I_0 ,

Q. No.

Value Points

Marks

Through P_1

$\frac{1}{2}$

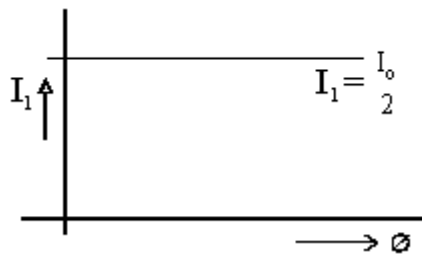

1

The light passing through P_1 remains constant i.e. $\frac{I_0}{2}$

The light passing through P_2 varies with θ as per the relation, $I_2 = I_1 \cos^2 \theta$

The light coming from a clear portion of the sky is nothing but sunlight that has changed its direction due to scattering by molecules in the earth's atmosphere. This scattered light is polarised. It, therefore, shows a variation in intensity when viewed through a polaroid on rotation.

2

Through P_2

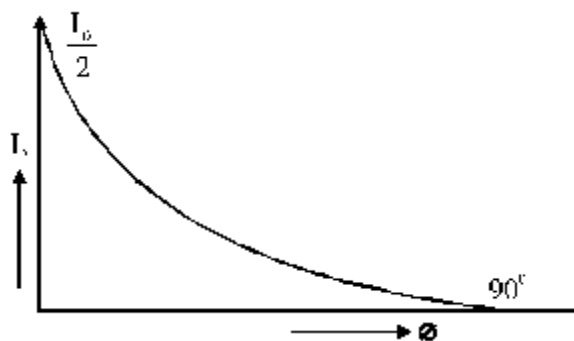

30. Circuit diagram for drawing the input and output characteristics.

1

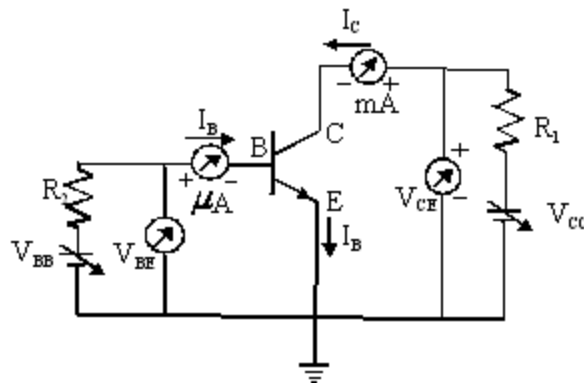

Typical shape of the input characteristics.

$\frac{1}{2}$

Q. No.

Value Points

Marks

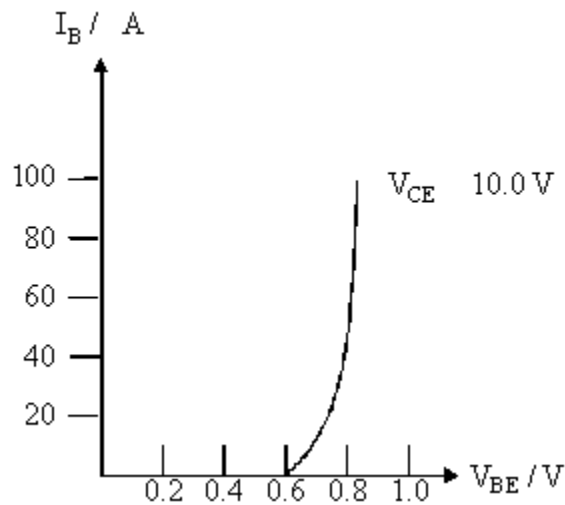

Cut off Stage : When the input voltage is less than a minimum value (≈ 0.6 V for Si), there is no current flow in the input or output sides of the transistor. The transistor is then said to be in its 'cut-off' stage. 1

Active Stage : This is the stage of the transistor when the input is greater than about 0.6 V and there is some current in the output path. 1

Saturation stage : With increase in the input voltage beyond a certain value, the output voltage decreases and becomes almost constant at a near to zero value. The transistor is then said to be in the saturation state. 1

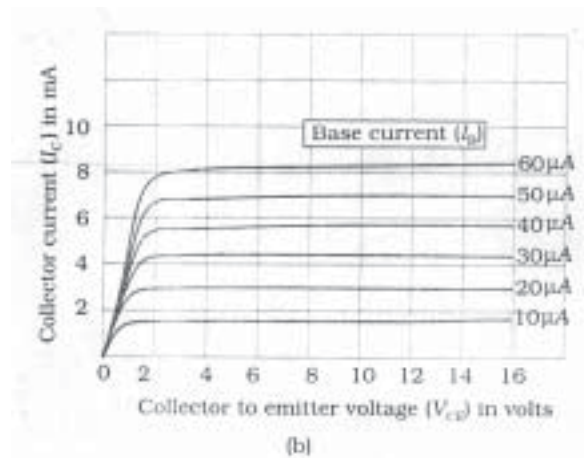

The Transistor does not remain in the active stage when it is being used as a switch. $\frac{1}{2}$

OR

The output C_1 is the output of an AND gate having \overline{A} and B as its two inputs. $\frac{1}{2}$

The output C_2 is the output of an AND gate having A and \overline{B} as its two inputs. $\frac{1}{2}$

The output Y is the output of an OR gate having C_1 and C_2 as its two inputs.

1/2

Using the truth tables for AND and OR gates, we can or therefore get the wave forms shown for C_1 , C_2 and Y.

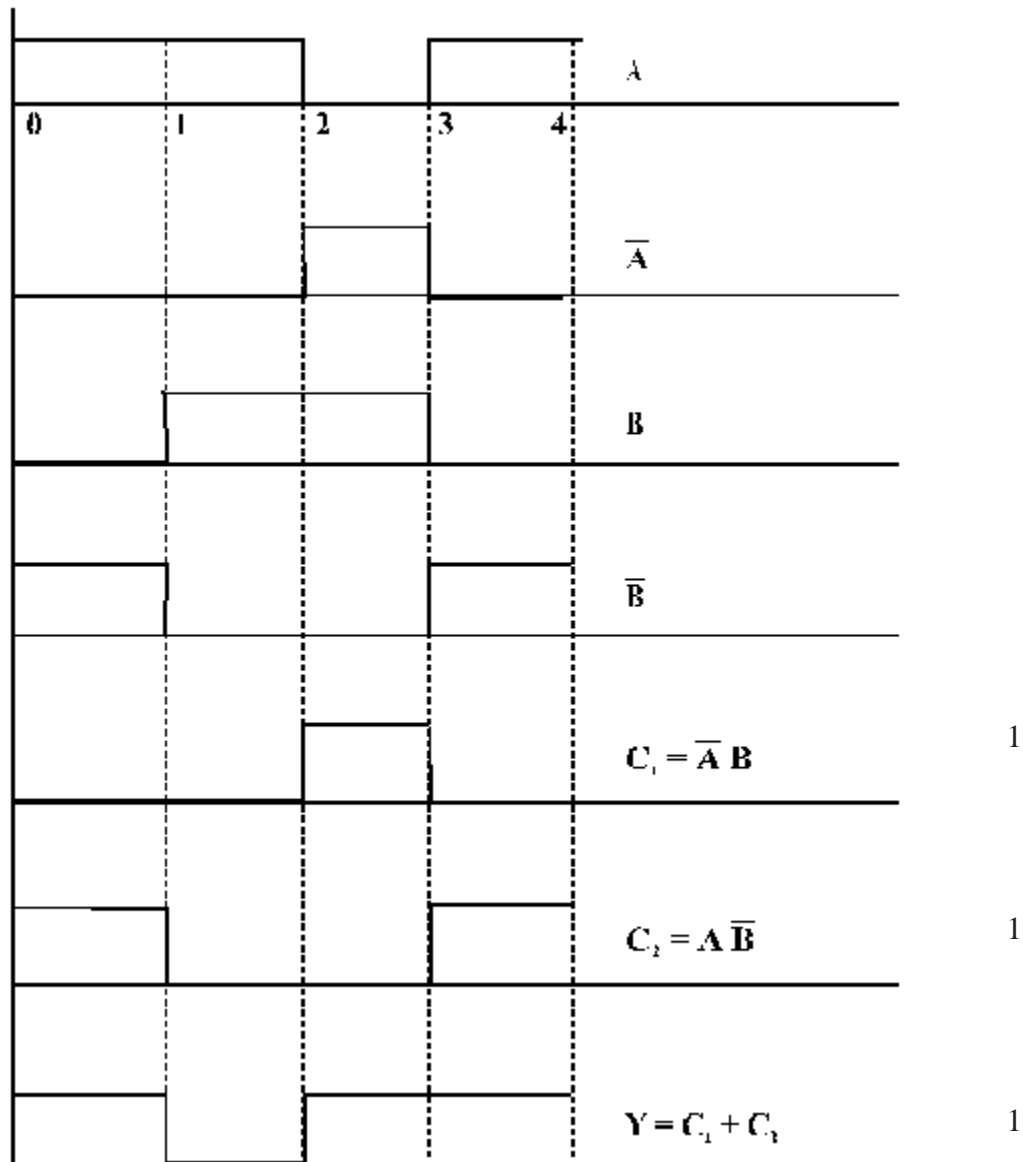

Looking at the shapes of A, B and Y, we can say that :

- (1) The output Y is low when both A and B are high.
- (2) The output Y is high when one of the input signals is high while the other is low.

1/2